

3/4" TC-X202 Series (Non-Metallic)

The TC-X202 3/4" pumps are available in Glass Fiber Reinforced Polypropylene (PPG) with a PPG air motor section for exceptional chemical resistance. Featuring new Looped C™ Air Motor Technology (patent pending). Both Flange and Threaded connection models are available.



Maximum Flow Rate: 31.7 GPM (120 L/Min)
 Maximum Discharge Head: 230 ft (70 m)
 Available in: Glass Fiber Reinforced Polypropylene and PVDF (Kynar®)
 Shuttle valve type: C-Spring Valve
 Certification: CE



SPECIFICATIONS		
Material Code*	P"X" (-FL)	PT (-FL)
Max Flow Rate	31.7 GPM (120 LPM)	26.4 GPM (100 LPM)
Max Air Pressure	100 PSI (0.7 MPa)	
Max Air Consumption	42.4 scfm (1200 L/min)	49.4 scfm (1400 L/min)
Supply Air Pressure Range ¹	30-100 PSI (0.2-0.7 MPa)	
Liquid Discharge Volume per cycle	12 oz (350 mL)	8 oz (240 mL)
Connection Suction x Discharge	NPT 3/4"	ANSI 150 lb 3/4" JIS 10 K20A (DIN 20PN10)
Weight	15.4 lbs (7.0 kg)	

* See Chart and Model Number nomenclature on back page for materials
 Note 1: A supply air pressure of 30 PSI (0.2 MPa) or more is required to operate the pump. If the supply pressure is less than 30 PSI (0.2 MPa), the pump may not operate properly.
 Pump Liquid Temperature Range: 32-140°F (0-60°C)
 Ambient Temperature: 32-158°F (0-70°C)
 Slurry Recommendation: 2mm or less
 Viscosity Limit: Suction Lift ~ 3000 cps (3 Pa·s) Force in ~ 8000cps (8Pa·s) (Pumping slurry is dependent on pump size & materials. Please contact your distributor for more details)

PERFORMANCE CURVES

— Flow
 - - - - Air

Conditions:
 4" flooded suction.
 Ambient temperature: 68-77°F (20-25°C)
 Liquid temperature: 68-77°F (20-25°C)

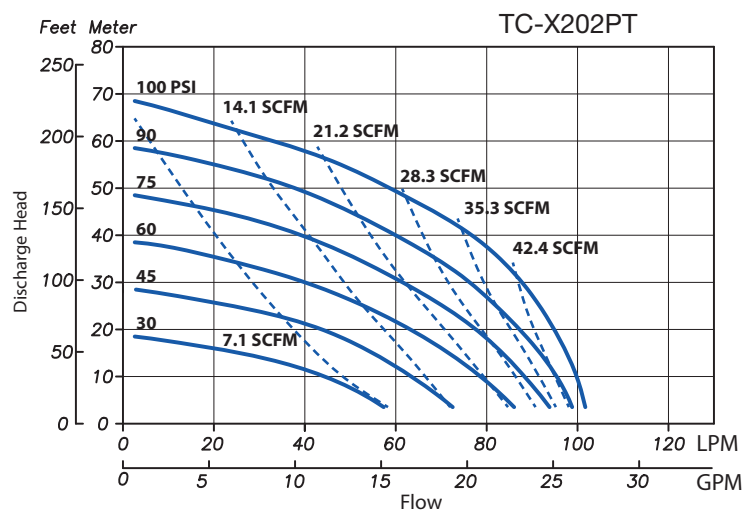
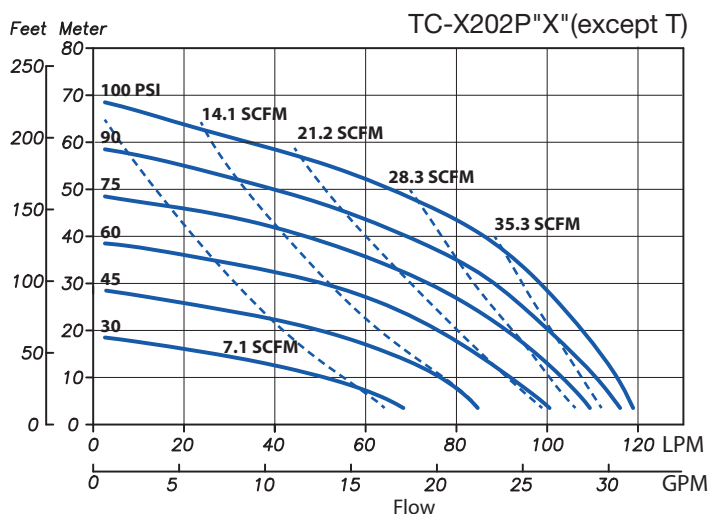

3/4" TC-X202 Series (Non-Metallic)

Model	TC-X202						
Part Name	PC(-FL)	PN(-FL)	PE(-FL)	PV(-FL)	PT(-FL)	PH(-FL)	PS(-FL)
Pump wetted parts	PPG						
Diaphragm	CR	NBR	EPDM	FKM	PTFE	TPEE	TPO
Ball O-Ring	CR/NBR	NBR	EPDM	FKM	PTFE	TPEE/NBR	TPO/EPDM
Valve Seat	PPG						
Center Disk	PPG (SCS13*)						

CR	Chloroprene Rubber (Neoprene™)	TPEE	Thermoplastic Polyester Elastomer (Hytrel™)
NBR	Nitrile Rubber (Buna®)	TPO	Thermoplastic PolyOlefin (Santoprene®)
PPG	Glass Fiber Reinforced Polypropylene	PVDF	Polyvinylidene Fluoride (Kynar®)
PTFE	Polytetrafluoroethylene (Teflon®)	*SCS13	Cast Stainless Steel (Insert Material)
EPDM	Ethylene Propylene Diene Monomer (Nordel™)	FKM	Fluoroelastomer (Viton®)

DIMENSIONS

TC-X202P (NPT)

TC-X202P (ANSI Flange)

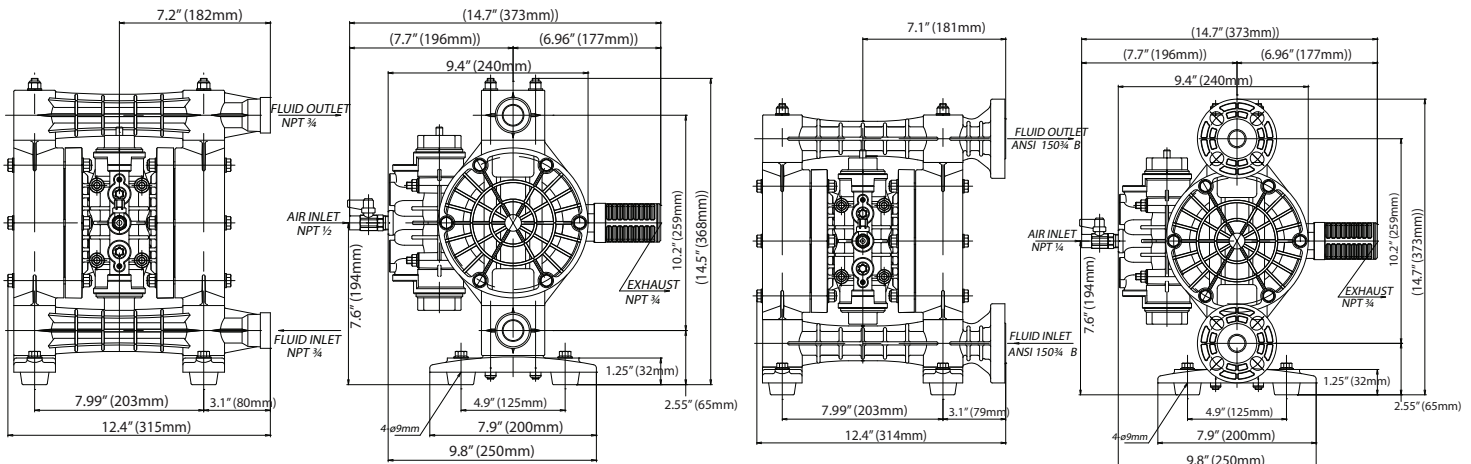

MODEL NUMBER NOMENCLATURE

